

Congratulations on your GearSpace™ 34 purchase. This cargo carrier is shipped pre-assembled in knock down form for freight shipment with minimal final assembly necessary. Be sure to review this instruction guide for complete information on how this cargo carrier system works and for important safety usage details that must be followed when operating a vehicle.

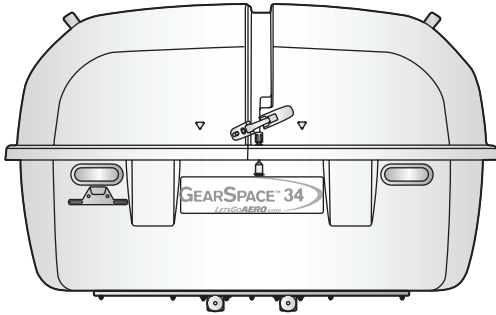

**Part One**

GearSpace™ 34 Installation Page 2

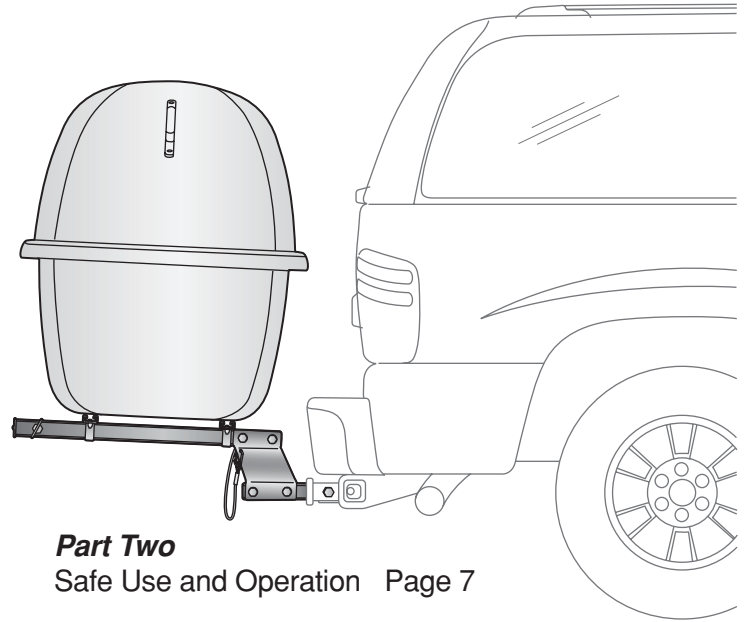

**Part Two**

Safe Use and Operation Page 7

**Installation Tips:**

- Keep this manual for future reference.
- The GearSpace™ 34 system fits a 2" size receiver style hitch and requires a minimum of a Class II tow rating.

*If this product was purchased from a dealer, all documentation MUST be furnished to the customer.*

**INSTALL GEARSPACE™ 34 ON HITCH RECEIVER**

The GearSpace™ 34 ships pre-assembled for quick and easy installation on the vehicle hitch. For safe and proper use, it is important to understand how the system works. The TwinTube™ steel structural platform for the GearSpace™ 34 Cargo Carrier is a system with two separate components that extend and enhance the load carrying capabilities of a receiver style hitch.

- The Spine assembly, which provides the carrier with its structural strength and telescope support.
- The Frame assembly, which provides the carrier with a mounting interface and telescoping function.
- Safety Cable Quick Links allow the Frame and Spine system components to be separated, thereby dividing some of the carrier’s weight

**STEPS OVERVIEW**

The installation procedures detail the following steps:

- 1 Install the Spine Assembly on the vehicle.
- 2 Secure the GearSpace 34™ Carrier on the Spine Assembly.
- 3 Secure the Safety Cable and connect the Wire Plug to the Vehicle Receptor.

**PARTS IDENTIFICATION**

**Parts List**

| <i>Item</i> | <i>Description</i>  | <i>Quantity</i> |
|-------------|---|-----------------|
| A           | Capsule Assembly  | 1               |
| B           | TwinTube™ Assembly (structural platform comprised of Frame and Spine Assemblies)    | 1               |
| C           | Silent Hitch Pins™ ( <b>installed on TwinTube™ Spine Assembly for shipment</b> )    | 2               |
| D           | Stainless Steel Adjustable Pin Lock with Set of Keys (secured to lids for shipment) | 1               |
| E           | Paraffin Starter Wax  | 1               |

| <b>Tools Needed</b> |
|---------------------|
| 7/16" Wrench        |
| 15/16" Wrench       |

*If you are missing any items, contact your sales agent if the product was assembled by them. If not, or if purchased from Let's Go Aero, please contact us at 1-877-GO-4-AERO (464-2376). Any shortages must be reported within 14 days of the purchase date.*

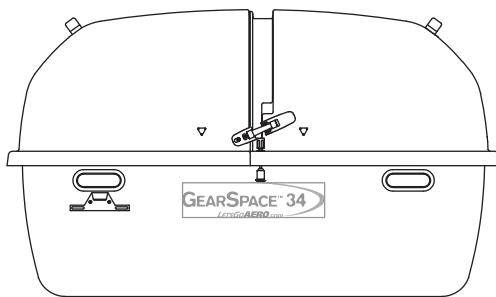

**Capsule Assembly**

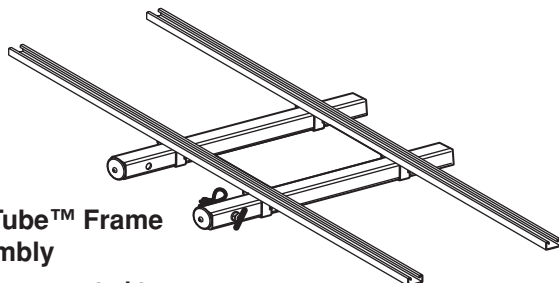

**TwinTube™ Frame Assembly**  
(Factory mounted to GearSpace 34 Capsule)

**TwinTube™ Spine Assembly**

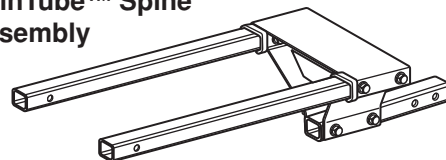

**SECURE SPINE ASSEMBLY IN HITCH**

Two Silent Hitch Pins are included with the carrier as part of the Spine Assembly to prevent the inherent rattle that occurs when placing an accessory device (in this case, the carrier) into the receiver hitch. The installation process is the same for both Silent Hitch Pins, the Hexhead Silent Hitch Pin™ secures the Spine Assembly to the receiver hitch and the Hand Tighten Silent Hitch Pin™ secures the Frame Assembly to the Spine Assembly.

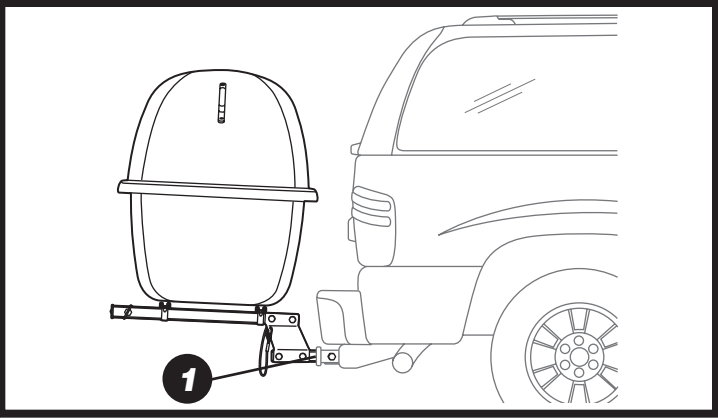
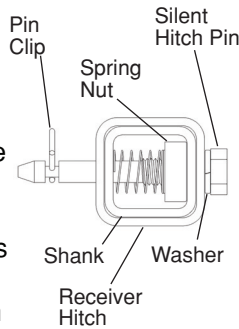

**Note:** Use the bolt hole in the Shank that places the Spine Assembly as close to your vehicle as possible. If more clearance is needed, re-position the spring nut to the last hole in the Shank and use this hole. If further clearance is needed, see page 5. LGA also offers a Hollow 7" Extension with Silent Hitch Pin™ accessory option for additional clearance. To purchase, contact LGA at 877-464-2376.

**Note:** The Spine's Fixed Tubes have been pre-waxed. A bar of Paraffin Wax is included for occasional reapplication by rubbing the top, sides and corners of the Fixed Tubes. This reduces friction, provides telescope smoothness, and protects the powder coated paint from wear. You will find that the Paraffin Wax is a great solution to clean, hassle-free operation. Once applied, it stays put and stays clean.

**Note:** When installing the Spine Assembly, make sure that the Fixed Tubes are **above** the shank and the vehicle hitch as shown here.

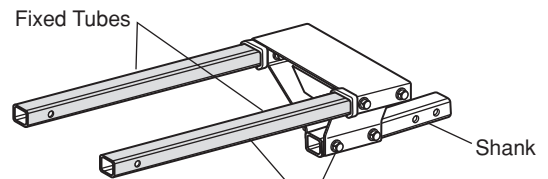

Make sure Fixed Tubes are above Shank when installing on vehicle

**WARNING**

The Silent Hitch Pins™ must be threaded into the Spring Nut, located inside the Shank, and firmly tightened to work properly. Make sure you use the Hexhead Silent Hitch Pin™ to attach the Shank to the receiver hitch. Use a wrench to securely tighten it to 30-60 ft. lbs. of torque.

**1. A threaded Spring Nut has been pre-installed in the Shank and should always be positioned to receive the Silent Hitch Pin.** If you use a different hole for clearance purposes, the Spring Nut must be moved to the hole being used. Always use the hole that places the Spine Assembly as close as possible to the vehicle.

Remove the Pin Clip and unthread the Hexhead Silent Hitch Pin™ from the Shank. Orient the Shank with the two 5/8" holes toward the receiver hitch on the vehicle. Slide the Shank into the hitch and align the hole with the Spring Nut with the hole in the hitch.

Make sure the Washer is on the Hexhead Silent Hitch Pin™ and thread it into the threaded Spring Nut. Use a wrench to securely tighten the Silent Hitch Pin™ to 30 - 60 ft. lbs of torque (equivalent to tightening a lug nut on a car wheel). Re-install the Pin Clip in the Silent Hitch Pin.

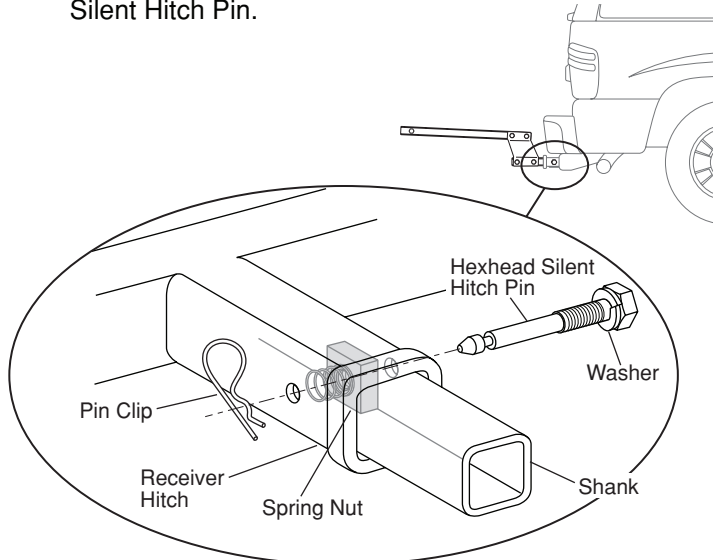

**SECURE THE GEARSPACE™ 34 CAPSULE TO THE SPINE ASSEMBLY**

The TwinTube™ Frame is pre-assembled on the GearSpace™ 34. The next step is to slide the carrier's Frame Telescope Tubes onto the Spine Assembly.

**2.** Remove the Hand Tighten Silent Hitch Pin™ from the Spine's Telescope-Safety pin hole and set it aside to be used later.

Slide the GearSpace™ 34 base with Frame Assembly onto the Spine with the Let's Go Aero logo and the reflectors on the tubes toward the rear.

**Note:** Up to 5" of additional clearance may be obtained by adjusting the position of the Frame's Wings along the Frame's Fixed Tubes. See page 5 for additional clearance adjustments.

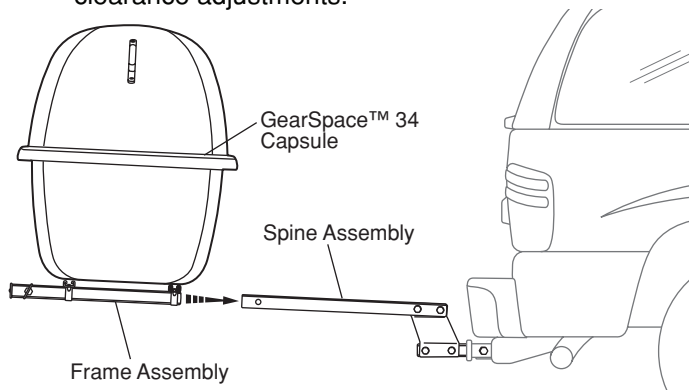

**3.** Re-install the Hand Tighten Silent Hitch Pin™ with the handle. This pin is for securing TwinTube's Frame with the GearSpace 34 Carrier to the Spine during use. When this pin is engaged, it helps prevent carrier movement or wobble. When in transit, it prevents the Frame from sliding rearward on the Spine. Be sure to use the 1/4" x 5/8" nylon bushing on the Silent Hitch Pin™ assembly to prevent any scratching or marring of the powder coated finish on the Telescope Tube. To install, thread the Hand Tighten Silent Hitch Pin™ into the spring nut that was pre-installed in the Spine's Telescope-Safety pin hole. Install the pin clip from the assembly.

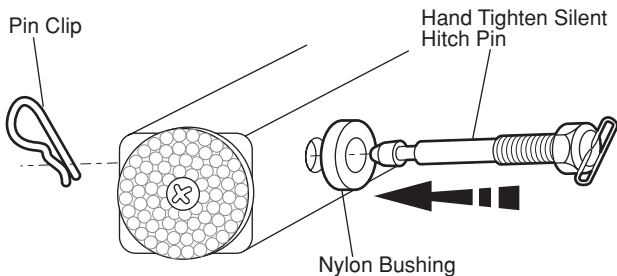

**!** **WARNING**  
The Hand Tighten Silent Hitch Pin **MUST** be firmly secured in Telescope-Safety pin hole location before transit. Failure to do so may result in potential hazards from improper operation, including property damage and bodily injury.

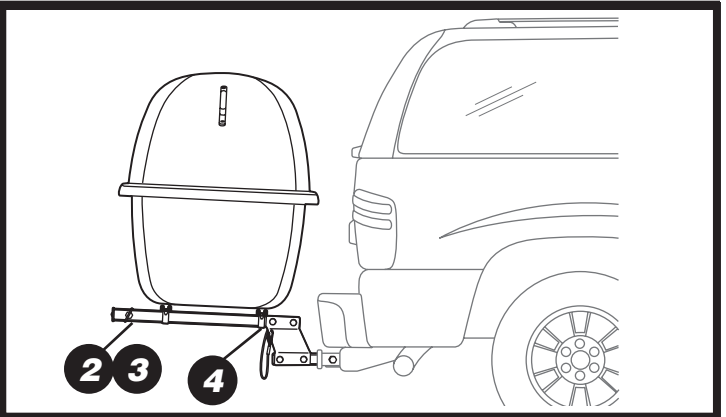

**!** **WARNING**  
Never move your vehicle with the Carrier extended in the telescoped position. It must always be properly secured before transit. Failure to do so may result in potential hazards from improper operation, including property damage and bodily injury.

**4.** Attach the Safety Cable to the passenger side V-Plate and the Safety Cable Retainer on the Frame using the Quick-Links attached to the cable. This will ensure that the Frame cannot slide off the Spine inadvertently. To remove the Frame and GearSpace 34™ Carrier from the Spine, simply undo one Quick Link. This allows TwinTube™ to be separated into its two component parts to ease the installation, removal and storage of the system.

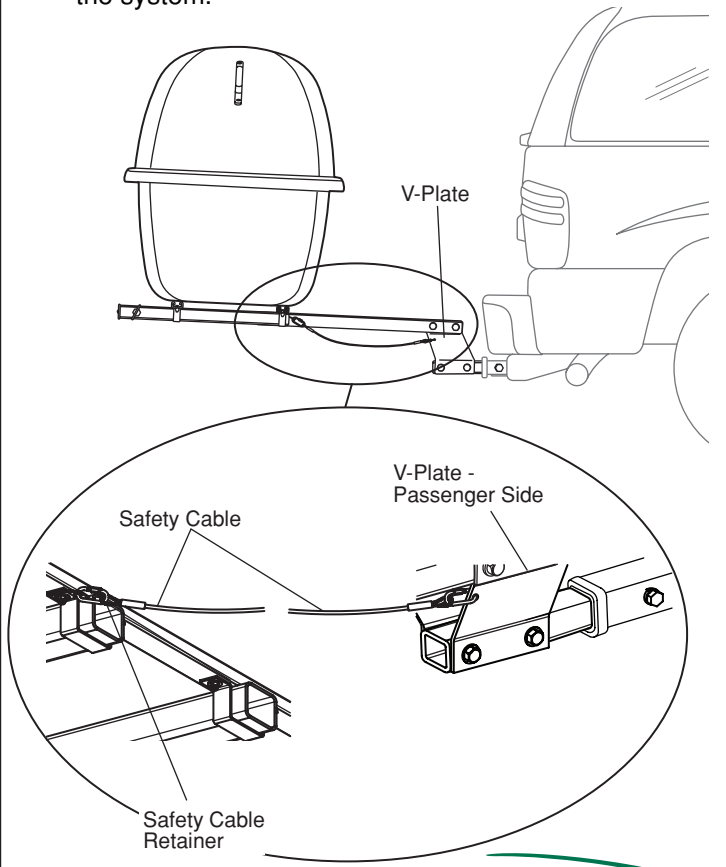

# GEARSPACE™ 34 CARGO CARRIER

## ADDITIONAL REAR CLEARANCE ADJUSTMENTS

The GearSpace™ 34 should be installed as close to your vehicle as possible. There are two hitch receiver bolt hole settings to choose from. You may also adjust the position of the Wings along the Frame Tubes for up to 5" more clearance from your vehicle. This gives you a distance of up to 10" from the vehicle when needed.

If you need more clearance, contact LGA to purchase an optional Hollow 7" Extension with Silent Hitch Pin accessory.

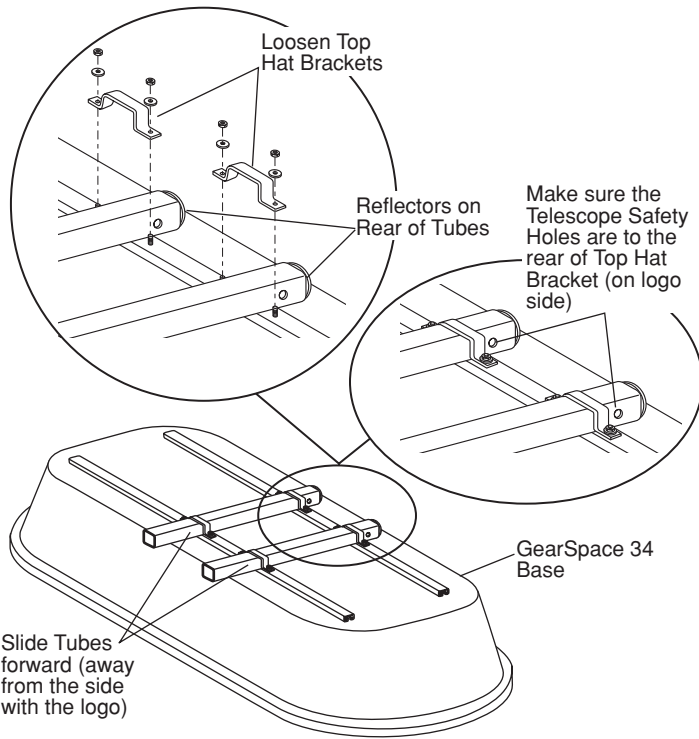

- To adjust the Wings, loosen the Top Hat Brackets and slide the Carrier rearward along the Frame's Fixed Tubes as close to the Telescope-Safety pin hole as necessary to give you the clearance you need. Retighten the Top Hat Brackets alternating from side to side.



### WARNING

Do not place the Top Hat Brackets outside the Silent Hitch Pin™ Telescope Safety Holes.

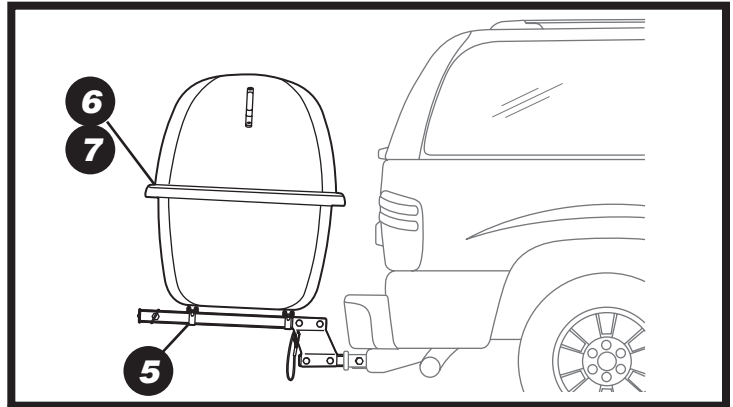
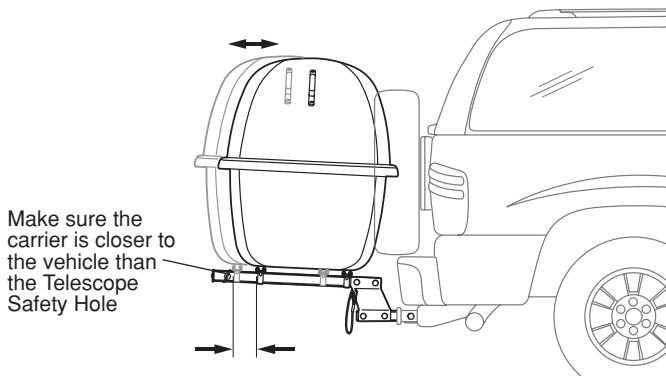

- Close the lids using the heavy-duty elastomer draw latches.

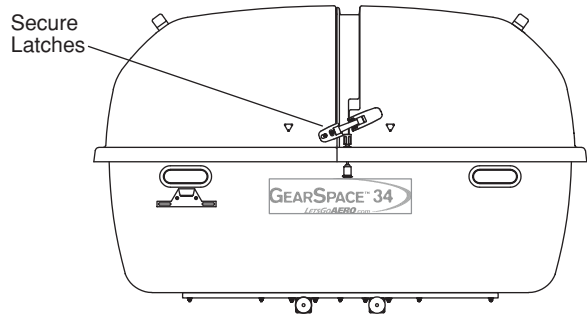

### WARNING

Never operate vehicle without securing the lids using both of the elastomer draw latches. Failure to do so will result in the lids opening in transit and property damage.

- Use the Stainless Steel Adjustable Pin Lock to lock the Carrier. Insert the rod from the top through the lid and base lip. Thread the barrel of the lock onto the rod. Turn the key to lock and remove the key.

**Note:** Contact Let's Go Aero to purchase an additional lock for use on the front of the carrier facing the vehicle.

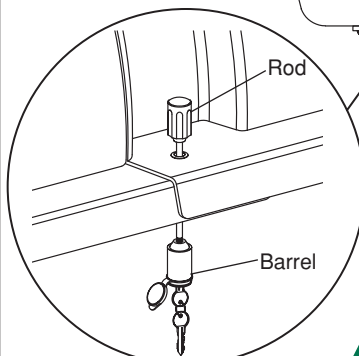
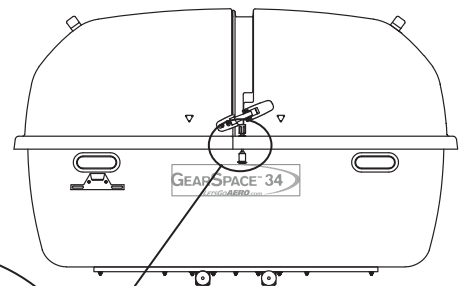

## GEARSPACE™ 34 CARGO CARRIER

### CONNECT WIRE PLUG TO VEHICLE RECEPTOR

- 8.** The GearSpace™ 34 lighting uses a four-flat connection. Connect this four-flat connector to the vehicle's wiring. Check running lights, brake lights, and turn signals before operation. Plug into vehicle receptor.

### LID ASSEMBLY

The lid on the GearSpace™ 34 may be easily removed to use it as an open carrier. For optimal operation of lids, please note the following factors.

- 9.** The V-Bar attaches from the lid to the base inside the capsule. To remove, squeeze the spring ends together to release the V-Bar. Pull the ends of the V-Bar outward to add tension and make sure that the V-Bar stays in place in the base.

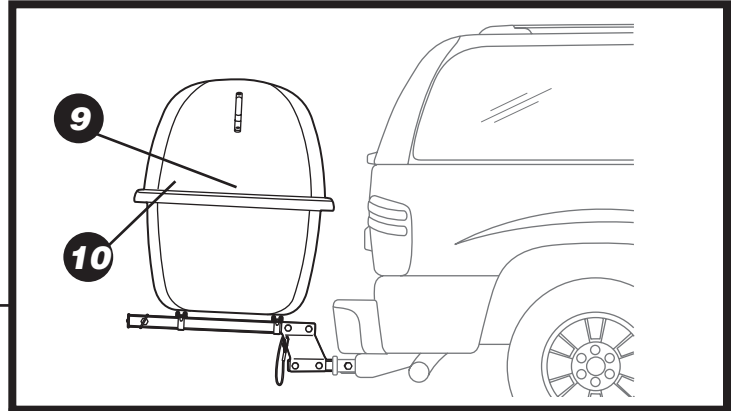
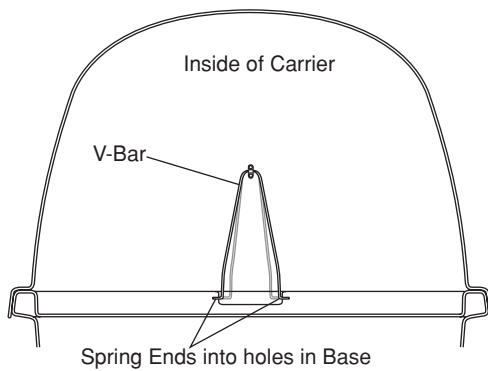

- 10.** The four (4) Throw Arms attach the lids to the base and guide the opening and closing of the lids. To remove the lids, remove the Retainer Clip from each Throw Arm Stud. Pull the Stud away from the Ball to disengage it.

To reinstall the Throw Arms, make sure to reinstall the Retainer Clips to keep the Studs from disengaging from the Balls.

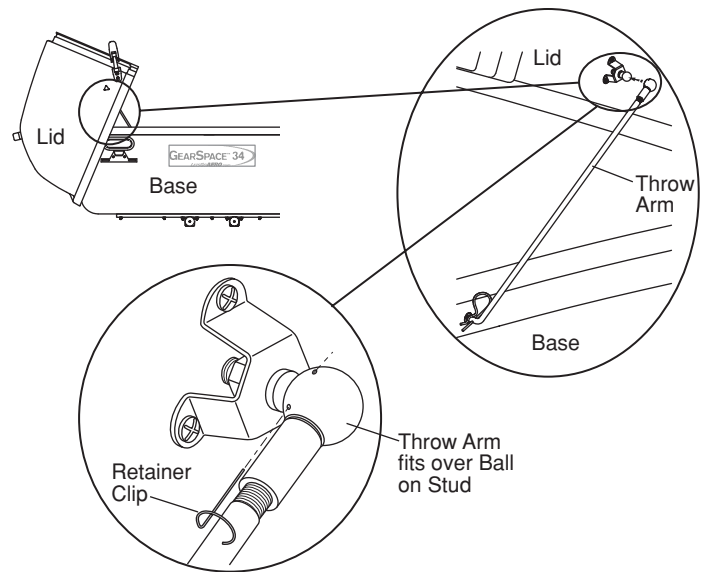

## **SAFE USE & OPERATION**

Be sure to follow these guidelines to prevent possible hazards from misuse.

### **Vehicle and Hitch Receiver Compliance**

This GearSpace™ 34 Cargo Carrier fits 2" size hitch receivers and is rated for a Class II tow capability or higher. When operating a tow accessory (any item inserted into the hitch receiver), you must comply with the vehicle and hitch receiver's towing parameters. Consult your vehicle and hitch receiver owner manual(s) for details on your tow and tongue weight parameters. Be sure that they are compatible with GearSpace™ 34's weight specifications.

### **Tongue Weight Compliance**

The GearSpace™ 34 and its cargo create a combined weight that creates direct downward pressure on the hitch receiver's tongue. This downward pressure is the tongue weight. Tongue weight is one of the two critical weight rating factors of your tow rating's classification. **Never exceed your vehicle and hitch receiver's tongue weight specification.**

### **GearSpace™ 34 Weight and Load Parameters**

The GearSpace™ 34 weighs 130 lbs unloaded. To determine your available load weight in accordance with your vehicle and hitch receiver's tongue weight rating, subtract GearSpace™ 34's 120 lbs from your identified tongue weight rating. The difference represents your vehicle and hitch receiver's available load weight.

The GearSpace™ 34 is rated for up to 300 lbs of cargo weight carrying capacity. When transporting cargo, place heavy loads in the center and lighter cargo to the outside.

### **Telescoping GearSpace™ 34 Cargo Carrier**

To telescope the GearSpace™ 34, remove the Hand Tighten Silent Hitch Pin™ from the Telescope Safety pin hole. Verify that the Safety Cable is secured and then slide the frame to the rear.

### **Lighting**

Check running lights, brake lights, and turn signals before operation. Check the wire harness for good connections and for possible fraying or wearing of insulation if a light signal is not functioning. Check lights before each use.

### **Locking Up GearSpace™ 34**

A stainless steel locking pin is included with the Carrier for locking down the GearSpace 34. The locking pin hole is located on the rear side of the Carrier for easy accessibility. A second pin hole is tapped on the front side of the carrier (facing the vehicle's rear) for use with a secondary lock, which is optional. Contact Let's Go Aero to purchase an optional lock at 877-464-2376.

**Note:** A set of keys are included with the locking pin. The key code is indicated on the keys and lock. Save this key code in the event of lost keys. A new set of keys may be purchased provided that they key code is indicated. Contact Let's Go Aero for assistance.

### **Maintenance**

The GearSpace™ 34 Cargo Carrier uses stainless steel hardware and a powder coated finish on the TwinTube™ structural platform for rust resistance. Periodically inspect for rust. If visible, remove the rust with emory cloth or fine sand paper and recoat with a lubricant. Do not use "WD-40" or other such spray lubricants on the slide tubes.

For smooth, clean sliding of the Frame on the Spine, a bar of Paraffin Wax is included. To apply, rub the top, sides and corners of the Fixed Tubes. This reduces friction, provides telescope smoothness, and protects the powder coated paint from wear. You will find that the Paraffin Wax is a great solution to clean, hassle-free operation. Once applied, it stays put and stays clean.

**SAFE USE & OPERATION CONTINUED****WARNINGS**

Failure to adhere to these recommendations may result in potential hazards from improper operation, including property damage and bodily injury.

- **Engage Silent Hitch Pins™**

Both pins MUST be securely engaged before transit. A wrench MUST be used to tighten the Hexhead Silent Hitch Pin™ at the hitch receiver location.

- **Secure the GearSpace™ 34 Cargo Carrier as close to vehicle as possible**

Always secure GearSpace™ 34 as close to your vehicle as possible, minimizing the distance of this structure and its load from your vehicle. There are two bolt hole settings from which to choose. You may also adjust the Wings for up to 5" of rear installed clearance from your vehicle as needed. See Step 6 of this User Manual for Wing adjustment.

- **Verify that the Safety Cable is Secured**

The Safety Cable prevents the Frame from sliding off the Spine when telescoping the GearSpace™ 34 Cargo Carrier. It should always be engaged for this reason, and to prevent the cable from dragging on the ground while in transit.

- **Never move your vehicle with the GearSpace™ 34 extended in the telescoped position.**

The GearSpace™ 34 must always be properly secured before transit.

- **Secure the GearSpace™ 34 Latches before Transit.**

Always secure the lids together before transit by pulling both draw latches over the receiver ends.

We warrant this product to the first consumer to be free from defect in material and workmanship for one year (Please retain your sales slip for your records). Any product or part thereof found to be defective within that period will be replaced without charge provided that: (1) the product was not misused; (2) no alterations or modifications were made; (3) its failure resulted from a defect in material or workmanship and not from normal wear expected in the use of the product; (4) the product or part is delivered, freight prepaid, to Let's Go Aero. Please contact Let's Go Aero, toll free, at 877-464-2376 to get a return authorization number prior to return. Manufacturers only obligation shall be to replace such products or parts proved to be defective.